

## Filter-15 Board

### General Description:

The filter board provides anti-aliasing filtering for up to 15 channels of analog signals. It is usually inserted between the analog processing board (ASTP) and the Analog-to-Digital Converter board (ADC) to suppress the aliasing of signals above the Nyquist frequency (Figure 3). The board uses elliptic filter modules (DP68L8EY) manufactured by Frequency Devices. These modules have a sharp pass-band to stop-band transition and high stop-band attenuation (100 dB). The filter characteristics are shown in Figures 4-6. Signal inputs and outputs are via the standard analog bus 16-channel, 20-conductor ribbon cable. Signals that do not need filtering are configured for pass-through by inserting a jumper instead of a filter module. Channel 0 is always a pass-through while channels 1-15 are available for filtering.

### Specifications:

#### Input/Output channels:

15 filter channels, 1 pass-through, Input/Output: 20-pin IDC 0.1"

#### Filter modules:

Frequency Devices, module DP68L8EY  
8-pole, 6-zero elliptic, 2.00 (-100 dB)  
Recommended cutoff frequency  $<0.66 \times F_{Nyquist}$

#### Power:

Supply:  $\pm 5V$  to  $\pm 15V$   
Current: 7mA (typical) to 10 mA (max) per filter module

#### Dimensions:

L 10.30" x W 3.00" x H 1.0" (267 X 76 X 26 mm)



Figure 1. Filter board

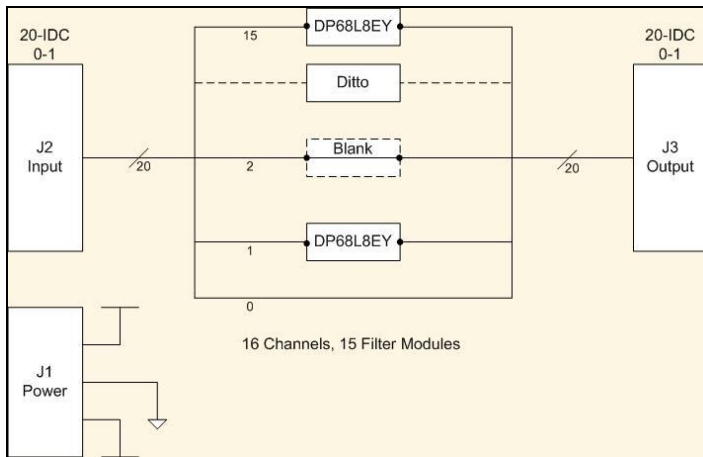

**Figure 2. Block Diagram**

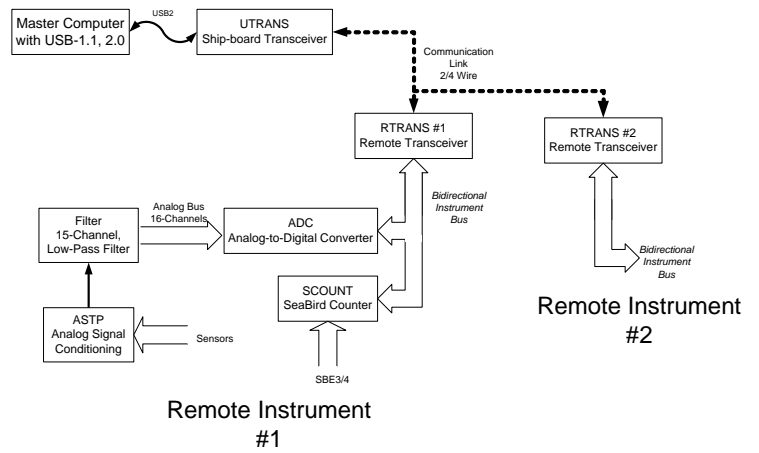

**Figure 3. Overview of the entire ODAS system.**

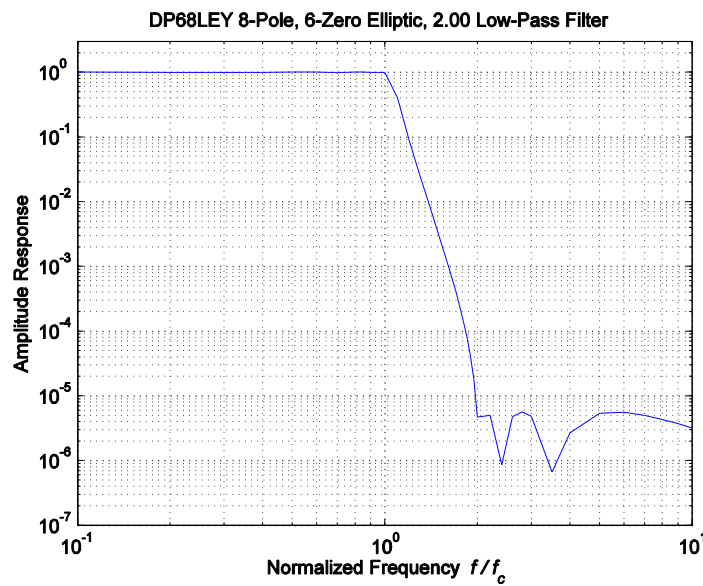

**Figure 4. Amplitude frequency response**

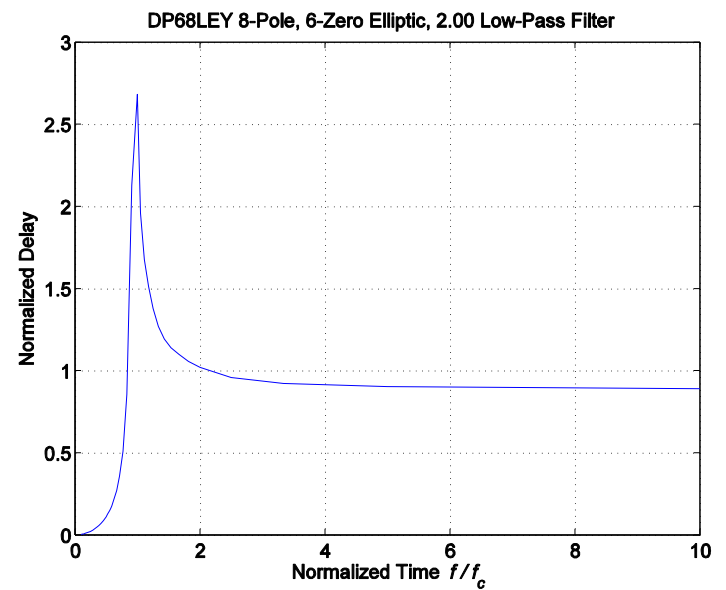

**Figure 5. Step response**

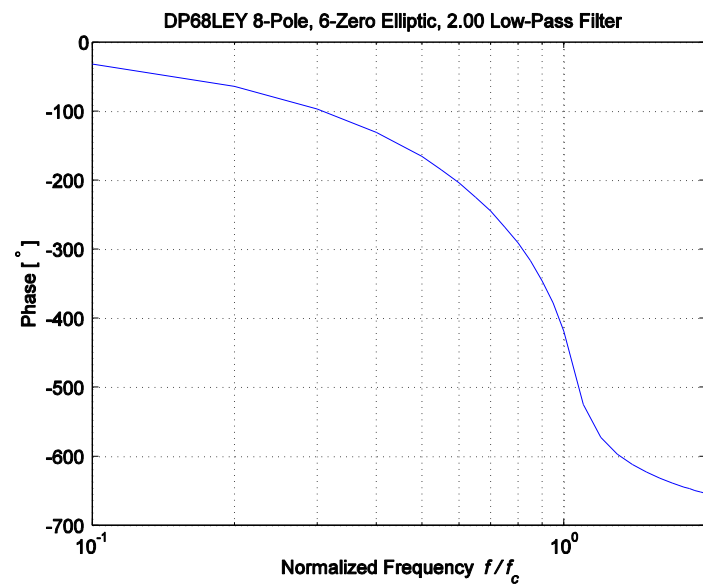

**Figure 6. Phase response**

**Connector List:**

J1 Power - Molex	
1	NC
2	+5V DC (+15V DC max)
3	-5V DC (-15V DC max)
4	NC
5	GND
6	GND

J2 Analog Input 0.1" IDC	
Pin #	Channel
1	0 (pass-through)
2	1
3	2
4	3
5	4
6	5
7	6
8	7
9	8
10	9
11	10
12	11
13	12
14	13
15	14
16	15
17	GND
18	GND
19	GND
20	GND

J3 Analog Output 0.1" IDC	
Pin #	Channel
1	0 (pass-through)
2	1
3	2
4	3
5	4
6	5
7	6
8	7
9	8
10	9
11	10
12	11
13	12
14	13
15	14
16	15
17	GND
18	GND
19	GND
20	GND