

microRider-1000

Modular, Self-contained Turbulence Profiler

Description

The microRider is a small instrument package for turbulence microstructure measurements, designed to integrate with a variety of instrument carriers, such as AUV, ROV, CTD rosettes, ocean gliders, and profiling floats. The microRider can carry

- Two shear probes (SPM-38-1),
- Two fast response thermistors (FP07-38-1),
- One micro conductivity probe (SBE7-38-1)*
- One high-resolution pressure sensor;
- and three high-resolution acceleration sensors.

The instrument is powered by 9 – 18 VDC and data are recorded internally on a memory card. The microRider will start recording as soon as power is applied. As an option, one external signal input or output (analog signal or frequency) is available, so that data records from the microRider can be correlated with other instruments' records. Sampling frequencies for individual channels can be set by software between 256 Hz and 4096 Hz, where 512 Hz is the recommended frequency for turbulence signals.

All signal channels are supported by proprietary low-noise signal conditioning circuits, which are carefully calibrated for frequency dependent gain to ensure maximum fidelity of the measured temperature variance and shear spectra. The data recording system consists of high-Q anti-aliasing filters (see our application note AN010 at www.rocklandscientific.com for details), a low-distortion A/D converter, and a computer running our Linux data acquisition system ODAS5-IR.

To improve the signal-to-noise ratio at high frequencies, the thermistor and pressure signals are provided both as a direct measurement (i.e., T and P) and as pre-whitened signals (i.e., T dT/dt and P 33dP/dt). The pre-whitening procedure is akin to the Dolby® Stereo noise reduction system.



microRider-1000-6

The internal 3D accelerometer pack provides vibration and attitude information. Since the microRider is designed to ride on a wide range of instrumentation platforms, the vibration data are of vital importance to the measurement. Narrow-banded platform vibrations that enter the signal frequency band can be tolerated because they can be removed using coherent signal processing techniques.

Data are recorded internally on a up to 16 GB memory card. The data acquisition is handled by a small computer system (CF2 Persistor) that is integrated inside the pressure case. The data are downloaded through a serial connection, through a bulkhead connector at the rear end cap. The data rate from the turbulence sensors is approximately 40 MB per hour (~ 1 GB per day). This assumes that the acquisition system is running all the time. The data acquisition can be turned on/off when needed via the two control lines on the end cap.

Power (9 - 18 VDC) is supplied by the supporting vehicle (AUV, ROV, glider, etc.) through one of the MHDG connectors on the rear bulkhead of the microRider. This connector has four pins: 2 for the power, the other two for supplying a "trigger signal" that triggers the data acquisition on or off. This is useful for putting the microRider "to sleep" to conserve power. Average current draw of the microRider is less than 100 mA (@ 15 V).

*optional

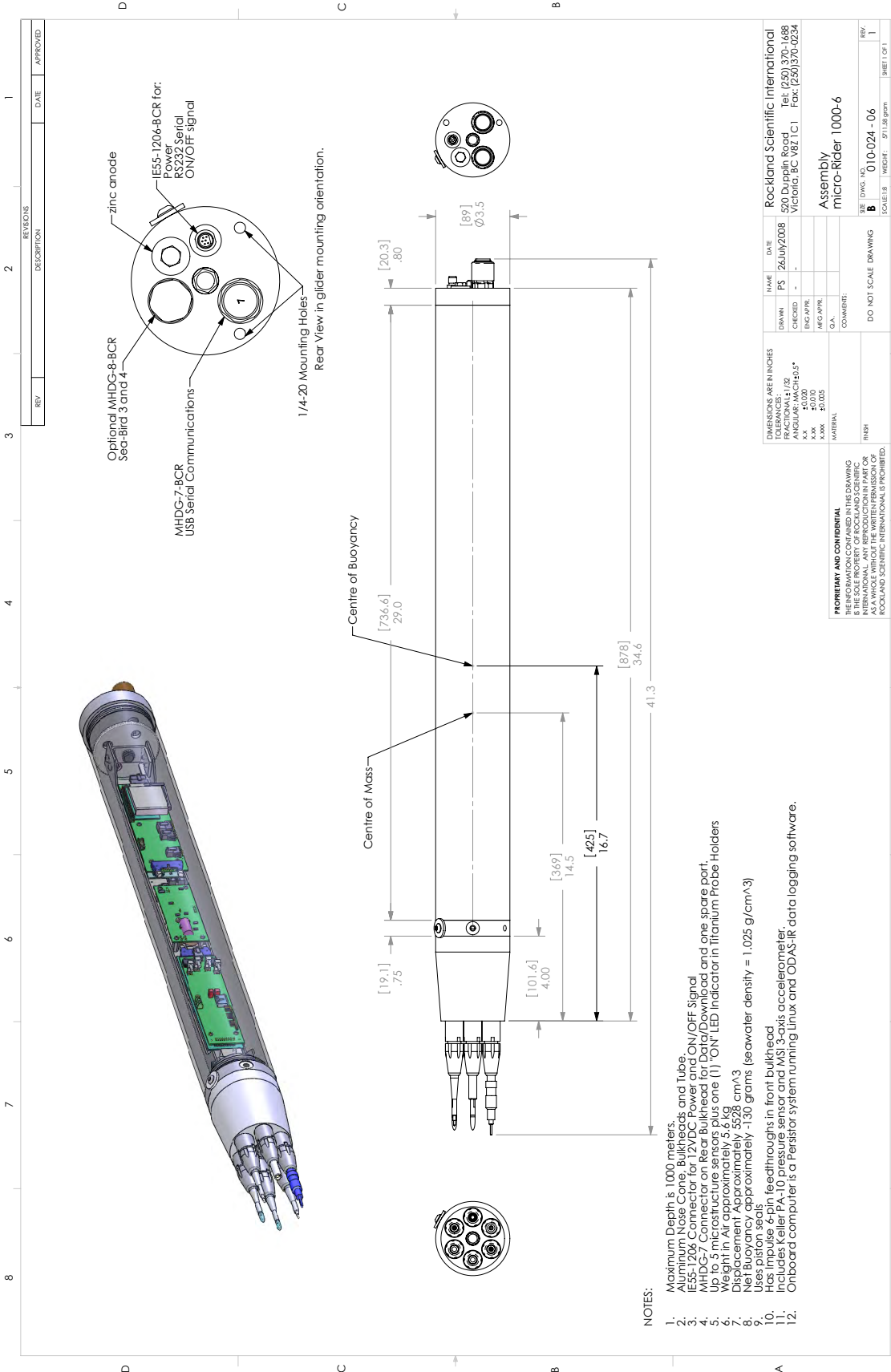

- NOTES:
1. Maximum Depth is 1000 meters.
 2. Aluminum Nose Cone, Bulkheads, and Tube.
 3. IESS-1206 Connector for 12VDC Power and ON/OFF Signal
 4. MHDG-7 Connector on Rear Bulkhead for Data/Download and one spare port.
 5. Up to 5 microstructure sensors plus one (1) "ON" LED Indicator in Titanium Probe Holders
 6. Weight in Air approximately 5.6 kg
 7. Displacement Approximately 3528 cm³
 8. Buoyancy approximately 150 grams (seawater density = 1.025 g/cm³)
 9. Uses 3 batteries
 10. Has impulse feedthroughs in front bulkhead
 11. Includes Keller PA-10 pressure sensor and MSI 3-axis accelerometer.
 12. Onboard computer is a Persistor system running Linux and ODAS-IR data logging software.

NAME	DATE	Rockland Scientific International
PS	26 July 2008	520 Dupont Road, Tel: (250) 370-1688
Victoria, BC V8Z 1C1		Fax: (250) 370-0234
DRWN	PS	
CHEK		
ENG APPR		
MFG APPR		
QA		
COMMENTS:		
DO NOT SCALE DRAWING		
SCALE	1:1	
DATE	15/04/2009	
SHEET NO	010-024 - 06	
SHEET OF	1	

PROBABLE AND CONFIDENTIAL
 THE INFORMATION CONTAINED IN THIS DRAWING IS THE SOLE PROPERTY OF ROCKLAND SCIENTIFIC INTERNATIONAL. IT IS TO BE USED FOR THE PROJECT AND AS A WHOLE WITHOUT THE WRITTEN PERMISSION OF ROCKLAND SCIENTIFIC INTERNATIONAL IS PROHIBITED.

15/04/2009

Features summary

- SPM-38-1 microstructure turbulence shear probes;
- FP07-38-1 microstructure fast thermistors;
- High resolution pressure sensor;
- Three-axis, high-accuracy accelerometers for measurement instrument attitude and vibration;
- SBE7-38 microstructure conductivity sensor;
- Support for Seabird SBE-3F / SBE-4C WOCE accuracy temperature and conductivity sensor;
- Anodized aluminium pressure case rated to 1000 m depth;
- Tapered nose cone to reduce flow deformation from pressure tube;
- On/Off indicator mounted on nose cone;
- On-board data acquisition with 4 GB memory (up to 16 GB available);
- High-fidelity signal conditioning using *signal + derivate* technique;
- ODAS5-IR real-time data acquisition software with up to 1024 Hz sampling rate;
- PLOT_ODAS library for MATLAB for data processing and display of turbulence spectra.

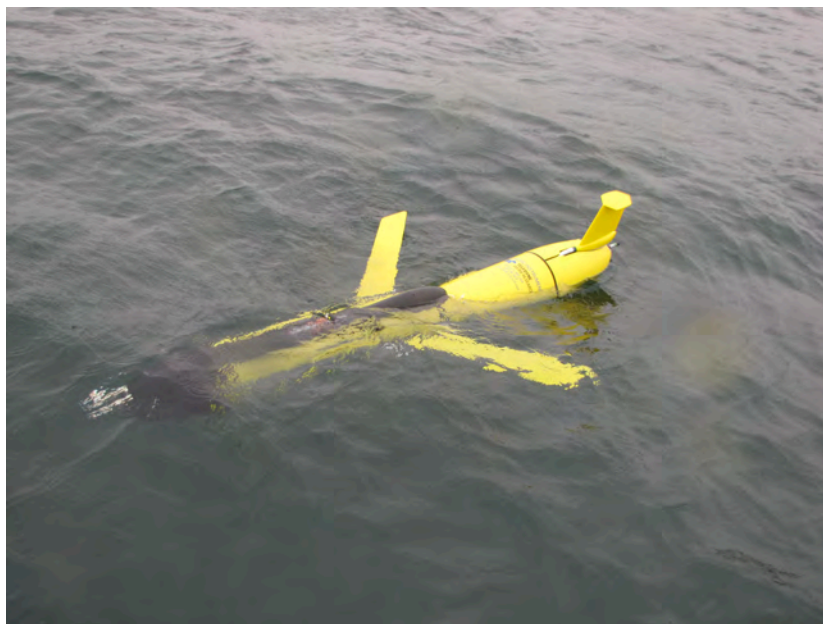
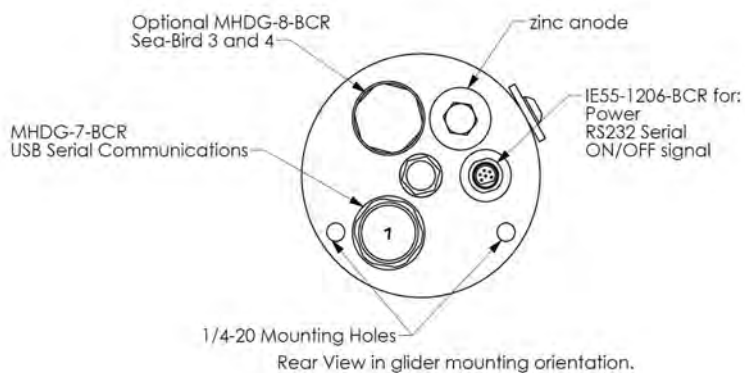
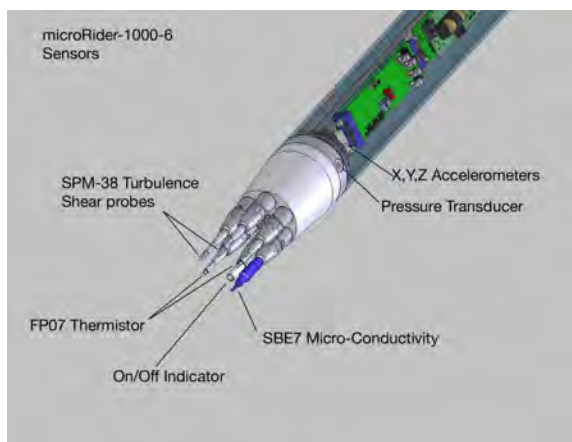

microRider on Slocum Glider



microRider on CTD rosette

Specifications

Pressure Rating	1000 dbar (up to 6,000 dbar available)
Analog input (optional)	-2.5V ... +2.5V or 0 ... +5VDC
Frequency input (optional)	for SBE3/SBE4 sensors
Power	9 – 18 VDC supply. Consumption: 1W operating, 10^{-5} W sleep.
Signals provided (depends on configuration)	Turbulence Shear (2x), T (2x), T+dT/dt (2x), C (2x), C+dC/dt (2x), P, P+dP/dt, Acceleration (3x)
Sampling rate	Nominal 512 Hz, up to 1024 Hz
Weight (in air)	~ 5.5 kg
Length overall	85 cm (pressure case), 102 cm (with probes)

Velocity shear

Range	$3 \times 10^{-10} - 10^{-4} \text{ W kg}^{-1}$
Accuracy	5%
Resolution	$2.5 \times 10^{-3} \text{ s}^{-1}$

Water temperature (SBE 3F)*

Range	-5 – 35 °C
Accuracy	$1 \times 10^{-3} \text{ °C}$ (NIST traceable)
Resolution	$1 \times 10^{-4} \text{ °C}$
Time Response	$0.070 \text{ s} \pm 0.010$

Micro Temperature (FP07)

Range	5 – 35 °C
Accuracy	N/A
Resolution	$1 \times 10^{-5} \text{ °C}$ (using signal + derivative technique)
Time Response	$0.007 \text{ s} \pm 0.003$

Conductivity (SBE 4C)*

Range	0 – 7 S/m
Accuracy	0.0003 S/m
Resolution	0.00004 S/m at 24 Hz
Time response	0.060 seconds (pumped)

Pressure (Keller)

Range	0 – 1000 dbar
Accuracy	0.1 %
Resolution	0.0005 dbar (using signal + derivative technique)

Analog/Digital Converter

Number of channels	15 + 1 (ground)
Resolution	16 bits (true)
Linearity	15 ppm

Accelerometers (IC Sensors)

Range	$\pm 2 \text{ g}$
Accuracy	0.5%
Resolution	$3 \times 10^{-5} \text{ g}$ (1 – 20 Hz)
Stability/Linearity	$\pm 0.5\%$, $\pm 0.01\text{g}$
Frequency response	0 – 300 Hz

Micro Conductivity (SBE7)[†]

Range	0 – 7 S/m
Accuracy	N/A
Resolution (spatial)	~ 5 mm
Time response	infinite

* Option. Requires SBE3-F or SBE4C sensor.

[†] Option.